

EclipseView Quick Guide

1 Introduction

Overview

Our general solution, based on the mobile surveillance software, cloud servers and smart terminal devices, is a new generation of IT-based solution that employs the technologies of cloud computing, mobile Internet and big data. Comprising mobile service and Web service, the solution aims to offer healthy, low-carbon, smart, comfortable and secure information services to small and medium sized enterprises.

Typical Networking

Solution A

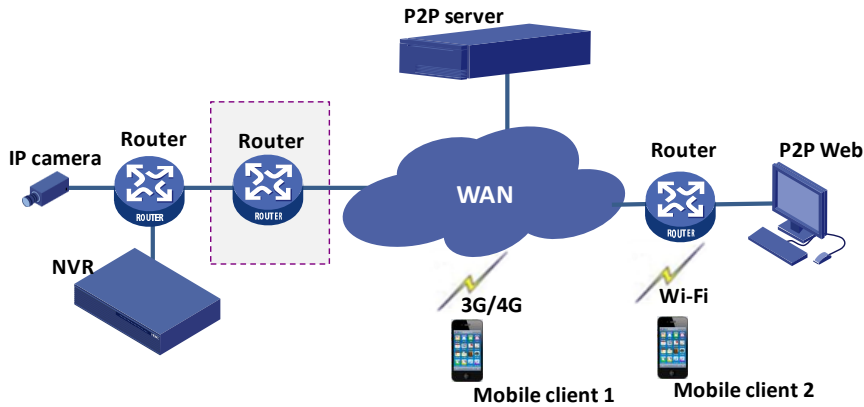

Solution B

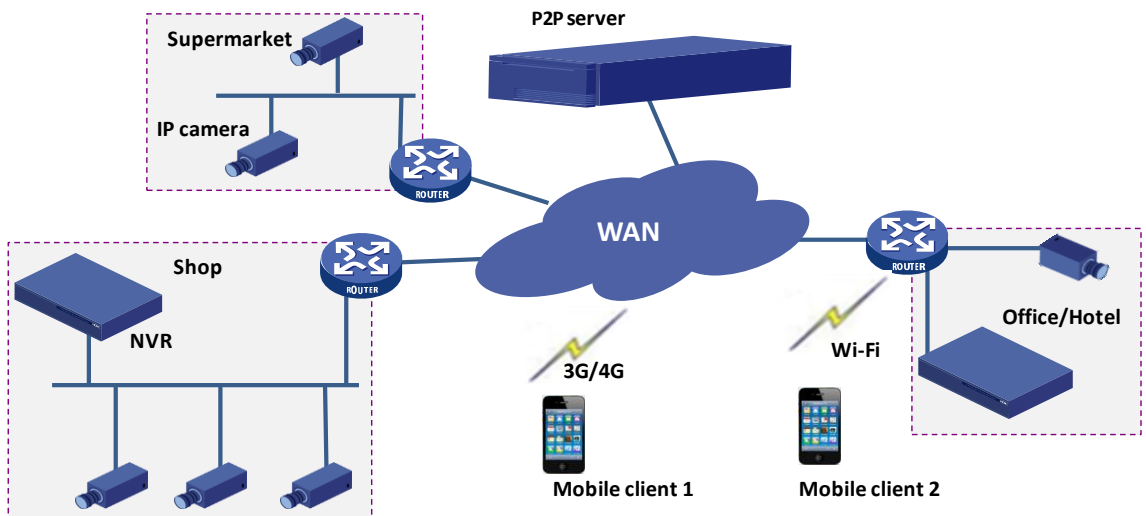

Installation and Connection

The terminal devices mentioned in this manual refer to IP cameras or network video recorders (NVR). For the installation of devices, please refer to the user document delivered with the devices. The connection of IP camera and NVR is illustrated as follows:

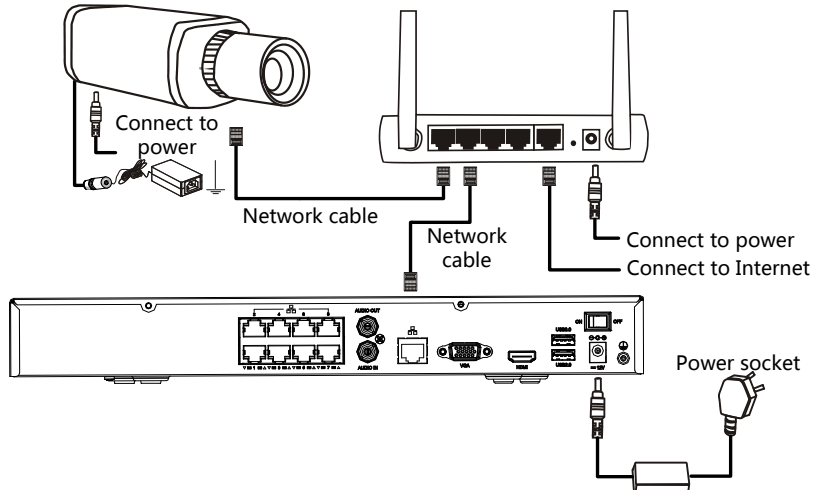

2 Mobile Service

Sign Up for a P2P Account

You need to sign up for a P2P account first before logging in to add, configure and operate a P2P device.

1. Open the app and tap **P2P Login**.
2. Tap **Sign Up** and complete the registration as instructed.

Log In

When opening the app for the first time, you can either log in with your P2P account or skip the login and experience the local functions.

- P2P Login: Log in to the app with your P2P account to add, configure or operate your P2P devices as required.

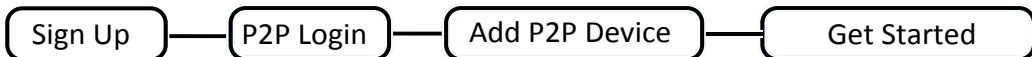

- Skip: Skip the P2P login to add, configure or operate your local device as required.



Skip

Tap **Skip** to enter the live view page. You can view live videos, play back recordings, manage files and more.

P2P Login

You need to have a P2P account to log in. To sign up for a P2P account, see Sign Up for a P2P Account.



NOTE!

The used usernames are saved in the username drop-down list on the login page. You may delete them as needed: For Android users, tap the delete icon to the right of each entry to delete it; for iOS users, slide the entry and tap to delete.

Add Devices

1. When logged in, tap **Menu** > **Devices**.
2. Tap to add devices or **Add P2P Device** to add P2P devices directly.
3. Select **Auto Search**, **Manual Add** or **Scan**. Follow the instructions to add the devices.

Auto Search

The app automatically searches for devices on the same network and allows you to add the discovered in batch.

Manual Add

- P2P

Scan the QR code on the device or enter the register code manually, or access the Web interface of the device and scan the QR code on the **P2P** page.

- IP/Domain

Enter the IP address of the device.



NOTE!

Only devices that support the P2P function can be added by P2P.

Scan



Add the device by scanning the QR code directly.

Play Live Videos

1. Tap **Menu** > **Live View**.
2. Tap or of the specified window to enter the camera list. Select one or more cameras and tap **Start Live View**.

Playback

1. Tap **Menu** > **Playback**.

2. Tap  or , and select the desired camera for playback.
3. Specify the start time of the playback and tap **OK**.

3 Web Service

Account Management

Sign Up

1. Go to www.eclipseview.com.
2. Click **Sign Up** in the upper right corner.
3. Enter the required information as instructed. You will be logged in after the registration is finished.

Log In

1. Go to www.eclipseview.com.
2. Click **Login**. Enter required information to log in.

Change Password

1. When logged in, click **Welcome xxx (your username) > Change Password**.
2. Change the password as instructed.

View/Change Information

View/Change User Information

When logged in, click **Welcome xxx (your username) > Personal Information** in the upper right corner. Change the email address as instructed.

View Log

1. When logged in, click **Welcome xxx (your username) > Show Log** in the upper right corner.
2. View the latest 10 entries of login information.

Device Management



NOTE!

To make full use of the management features of the Web service, please ensure the network accessibility of the managed devices.

Add Devices

1. When logged in, click **Device List** to go to the device list.
2. Click **Add Device**. Enter required device information as instructed and click **Add**.



NOTE!

The serial number of the device may be required when adding the device. You can access the device from a web browser and get its serial number. For details, please refer to the user manual of the device.

Add Organizations

You can add one or multiple devices to the same organization for easy management.

1. Click **Add Org** to enter the **Add Org** page.
2. Select the desired upper organization name, enter the organization name, and then click **OK**.
3. Click **Add Device**, enter the register code, device name, and select the new added organization. Then the device is added to the new organization.

Access Devices

1. Go to the device list.
2. Select the desired device and click **Access**. You will be redirected to the Web interface of the device.
3. Enter the username and password to log in to the device.

Share Devices

1. Go to the device list.
2. Select the desired device and click **Share**.
3. Enter required information as instructed and click **OK**.

4 FAQs

I cannot access my devices (NVRs/IP cameras) through the WAN.

Please follow the steps below to check.

1. Check whether you have registered a P2P account. If not, sign up for an account first.
2. Check whether the device is added to the P2P account:
Go to www.eclipseview.com and log in to check whether the device is listed under **My Cloud Devices**. If not, click **Add Device** or use the mobile phone client to add the device.

3. Check whether the P2P function is enabled for the device:

- IP Cameras

Go to the Web interface of your device and click **Setup** > **Network** > **P2P**. Check whether P2P is enabled and the **Device Status** is **Online** (connected to the P2P server).

- NVRs

Go to the Web interface of your device and click **Settings > Network > P2P**. Check whether P2P is enabled and the **Device Status** is **Online** (connected to the P2P server).